

TETRA BED

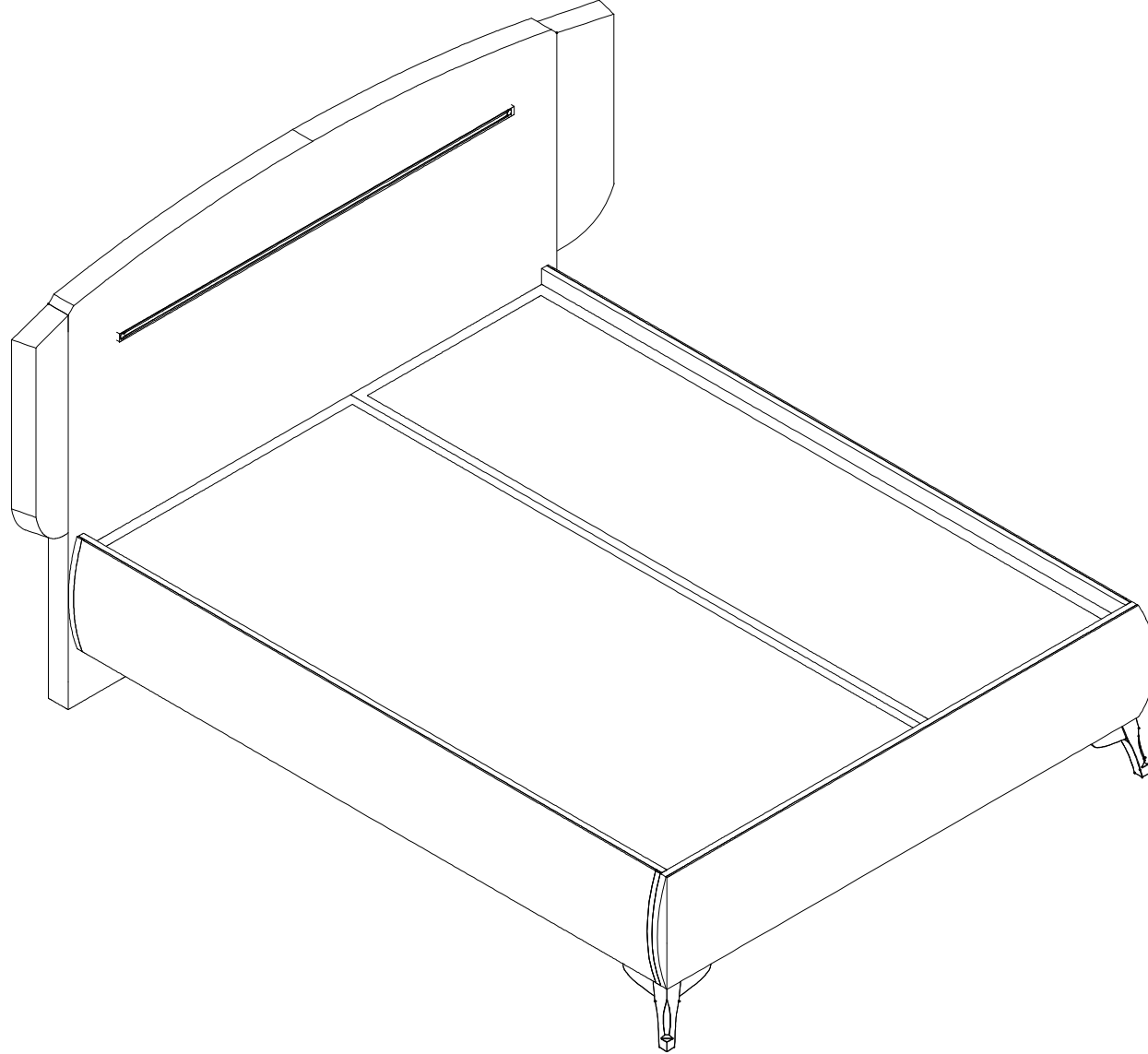

Assembly Instruction

Page 12/1

Sayın Müşteri,
Satin almış olduğunuz bu ürün size ulaşmadan önce tüm test edilmiş, kontrol edilmiş ve paketlenmiştir. Ancak nakliye sırasında bazı parçalar zarar görebilir. Böyle bir durumla karşılaşırsanız ürünün tamamını geri göndermeyin. ve sadece hasarlı parçayı ve malzemeyi isteyin.

Gerekli parça ve malzemelerin kodunu kurulumda bulabilirsiniz.

Manuel.

Montaja başlamadan önce kolilerden çıkan ürünler eksiksizdir. ve zararsız, olduğundan emin olun.

Birden fazla ürün satın aldıysanız montajı tamamlamadan tek bir ürünü, bitirmeden ikinci ürünü açarak karışıklık yaratmayınız. Kurulumu başlamadan önce her parçayı hafif nemli bir bezle silin ve kurulumu başlatın.

Başlayabilirsiniz.

Lütfen mobilyalarınızı amacı dışında kullanmayınız.

Dear Customer,

Before this product you have purchased reaches you, all of our has been tested and checked and packaged.

However, some parts may be damaged during transportation. If you encounter such a situation, do not send the entire product back. and simply ask for the damaged part and the material.

You can find the code of the required parts and materials in the installation manual.

Before starting the assembly, the products coming out of the boxes are complete and harmless make sure it is.

If you have purchased more than one product, without completing the assembly of a single product,

Do not cause confusion by opening the second product.

Before starting the installation, wipe each part with a slightly damp cloth and start the installation.

You can start.

Please do not use your furniture for other than its intended purpose.

PAKET İÇERİ / PACKAGE INCLUDED

PAKET NO PACKAGE NO	PARÇA NO / PART NO
1 PK	1
2 PK	2 3 4
3 PK	6
4 PK	PU
5 PK	AYAK AKSESUAR
6 PK	7 5

In case you need a sparepart, please indicate "Model Code" and "Accessory Code" shown in the assembly instructions.

LET'S PAY ATTENTION TO THE CODE AND LOCATION OF THE MATERIALS WHEN POSITIONING

TETRA BED

INSTALLATION DIAGRAM WITH SPARE PARTS

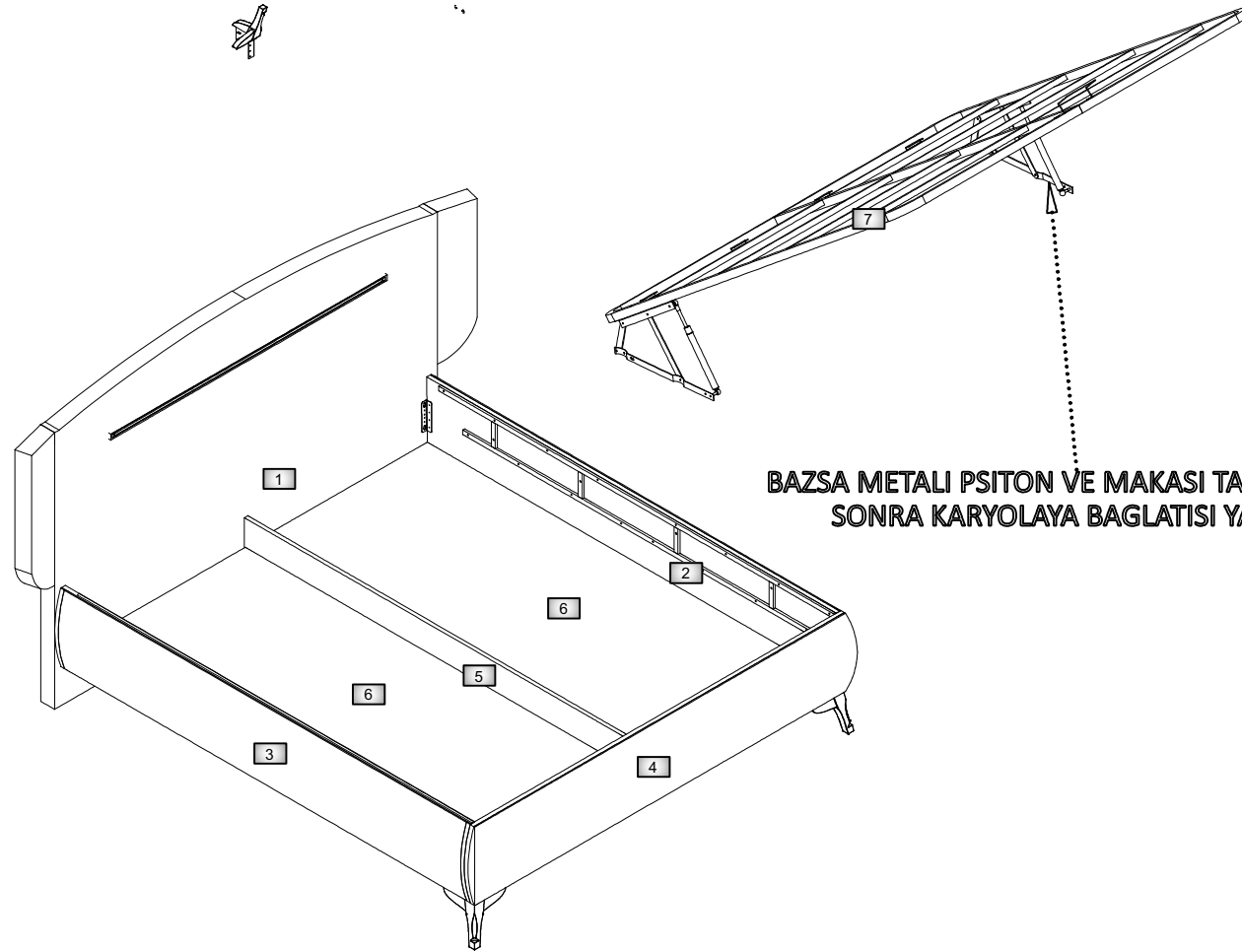

BAZSA METALI PSITON VE MAKASI TAKILDIKTAN
SONRA KARYOLAYA BAGLATISI YAPILIR

PARÇA KODU	PARÇA ADI	ADET
1	BEDSİDE TABLE / BASUCU TABLA	1
2	RIGHT SIDE TABLE /SAG YAN TABLA	1
3	LEFT SIDE TABLE / SOL YAN TABLA	1
4	RIGHT SIDE PANEL / AYAKUCU PANEL	1
5	ARA KAYIT / INTERMEDIATE REGISTRATION	1
6	UNDERBED CHIPBOARD / YATAK ALTI SUNTASI	2
7	KAPAK BAZA METALI	2

Code	Kod	E5	E2	AY	LD	BD	PU	ABV	ABV	ABV1	ABV2	ABV3	STP
Items	↳	3*9 CHIPBOARD SCREWS	3*9*25 CHIPBOARD SCREWS	FOOT	L-IRON	BED BED ADJUSTABLE BASE FOOT BAR	PLASTIC WASHER	ADJUSTABLE BALLS / YATAK ALTI DÜĞÜ M8*15	ADJUSTABLE BALLS / YATAK ALTI DÜĞÜ M8*15	ADJUSTABLE BALLS / YATAK ALTI DÜĞÜ M8*30	ADJUSTABLE BALLS / YATAK ALTI DÜĞÜ M8*30	ADJUSTABLE BALLS / YATAK ALTI DÜĞÜ M8*50	SPRING STOPPER
Quantities	↳	4	92	2	2	3	12	4	2	2	4	4	4
MATERIAL PICTURES													

In case you need a sparepart, please indicate "Model Code" and "Accessory Code" shown in the assembly instructions.

LET'S PAY ATTENTION TO THE CODE AND LOCATION OF THE MATERIALS WHEN POSITIONING

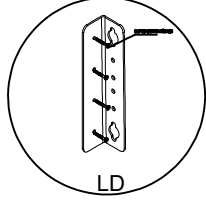

LD

(LD) KARYOLA BAGLANTI DEMIRI 3,5*25 (E2)
SUNTA VİDALARI İLE YAN TAHTAYA
MONTAJI YAPILIR.

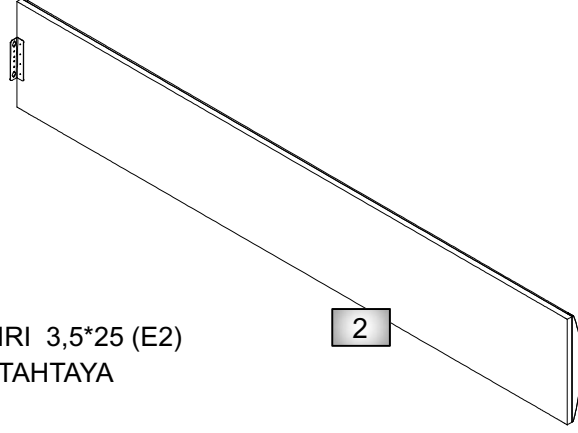

YAN TAHTAYA BAGLI KARYOLA BAGLANTI
DEMİRLERİ (LD) 3,5*25 (E2) SUNTA VİDALARI İLE
AYAK UCUNA MONTAJI YAPILIR.



E2

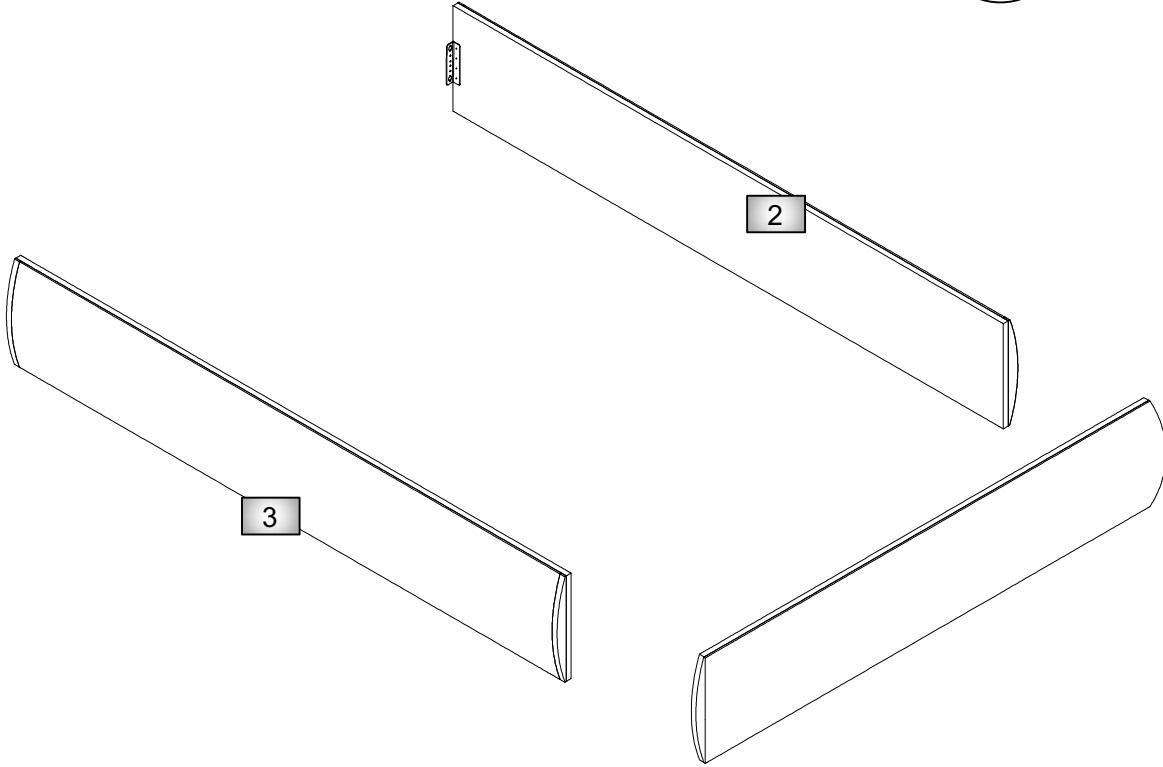

AYAKLAR AYAKUCUNA KÖŞEDEN AYAGA BAĞLI
L DEMİRLERDEN 3,5*25 SUNTA VİDALARI İLE
MONTAJI YAPILIR.

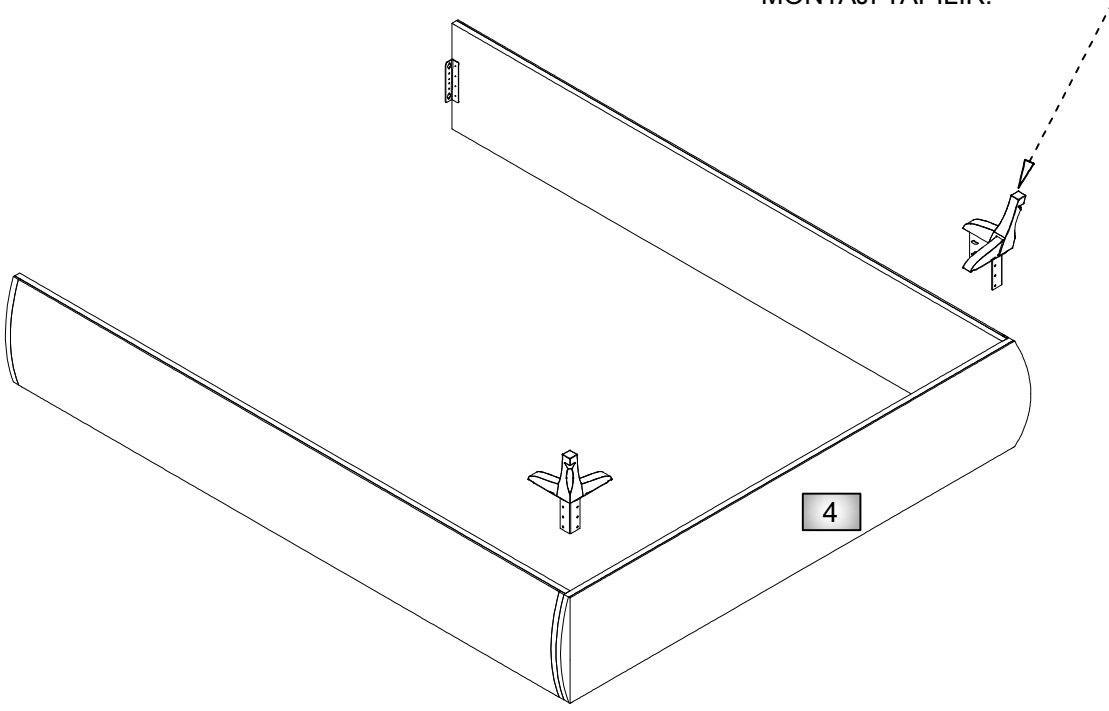

L DEMİRLERDEN SABİTLENEN AYAKLAR
AYAKLARIN ALT KISIMINDAN GÖSTERİLDİĞİ
SEKİLDE 5*70 (E5) SUNTA VİDASI İLE SABİTLENİR.

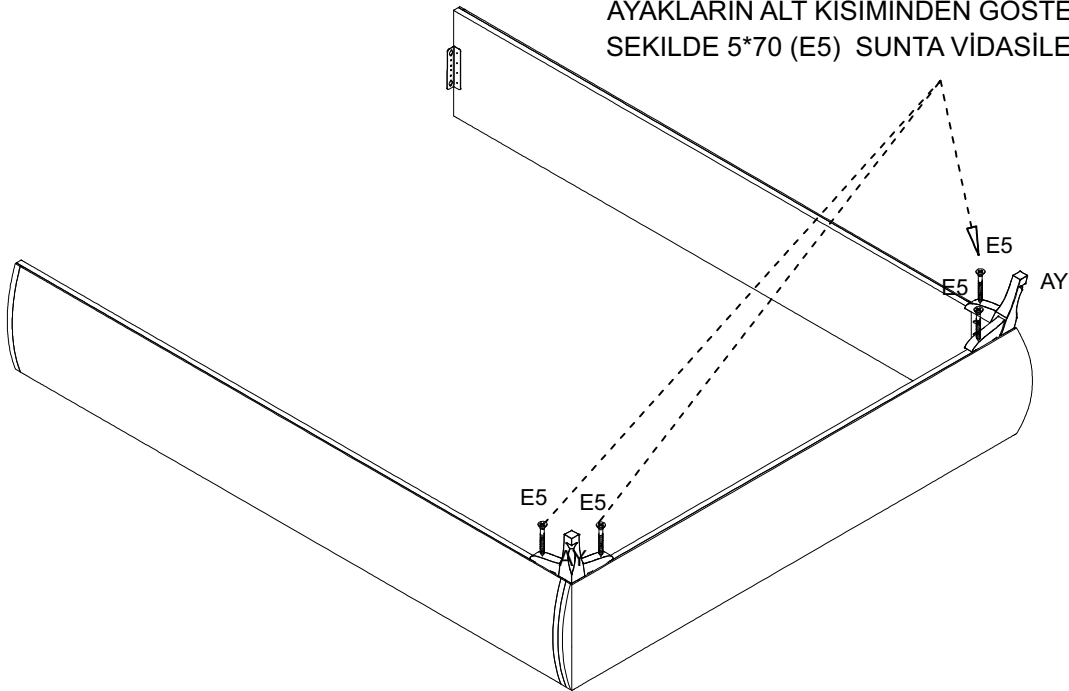

YAN TAHTA YERDEN 17.5 CM YERDEN YUKARDA
OLACAK SEKILDE L KARYOLA BAGLANTI
DEMIRLERİNDEN 3,5*25 SUNTA VİDALARI İLE
BASUCUNA MONTAJI YAPILIR.

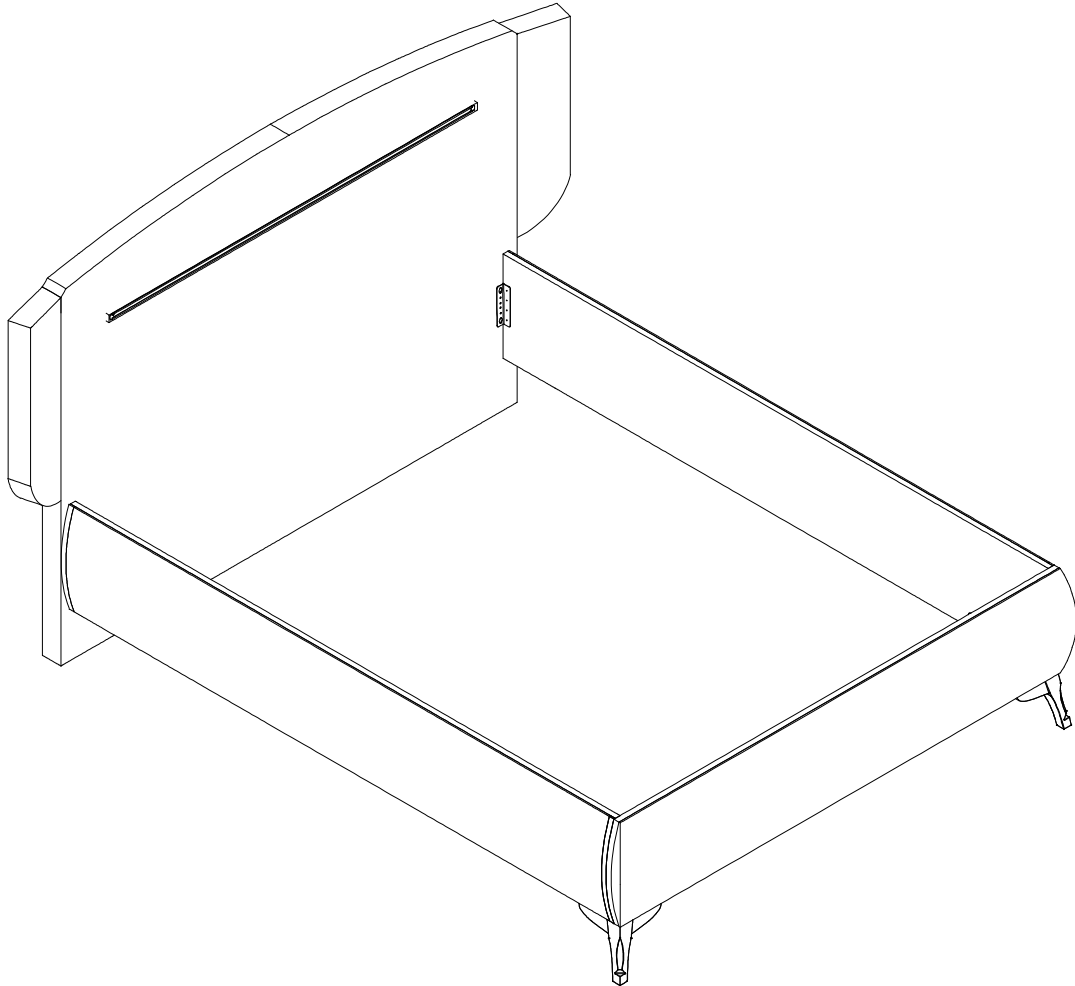
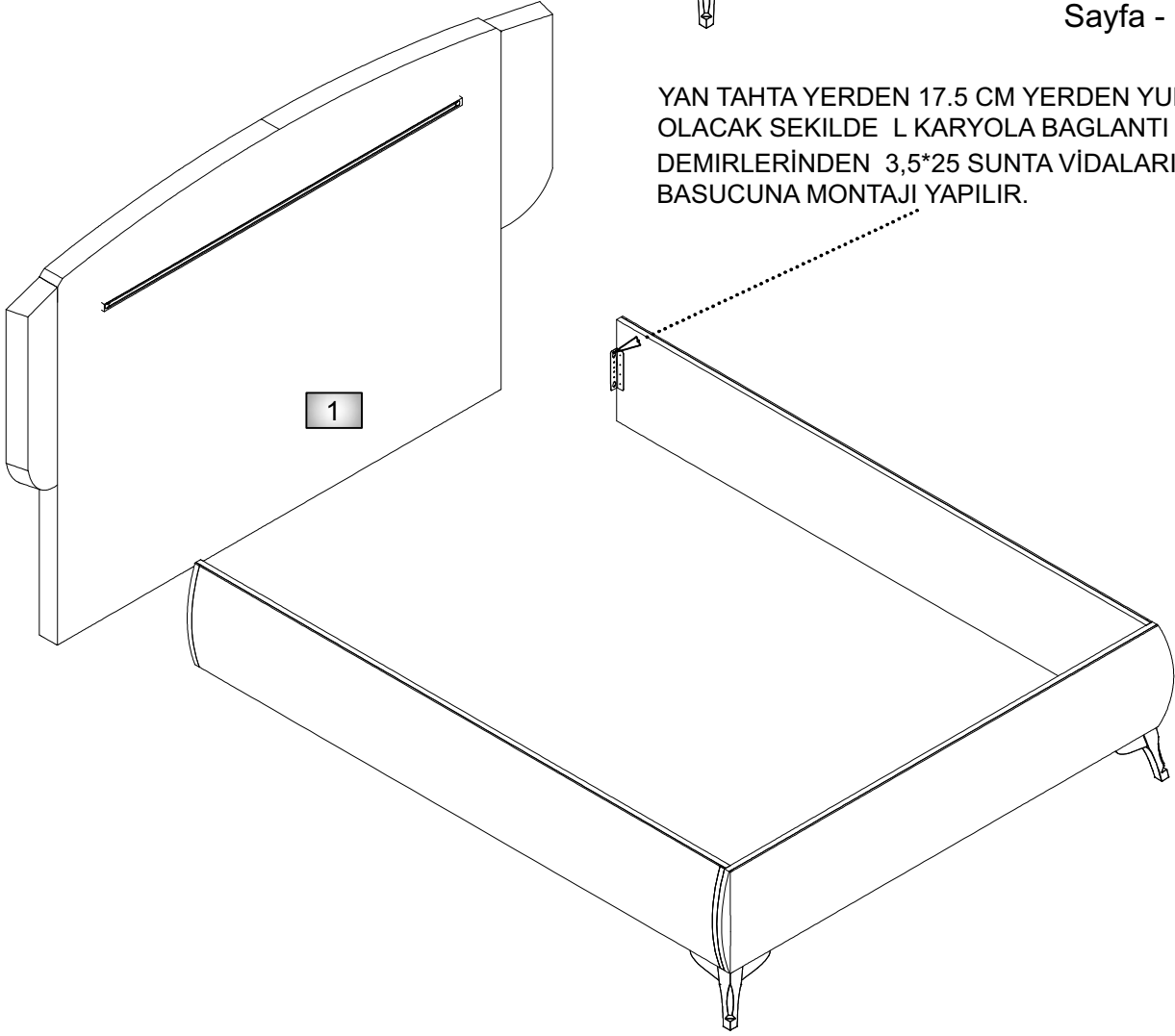

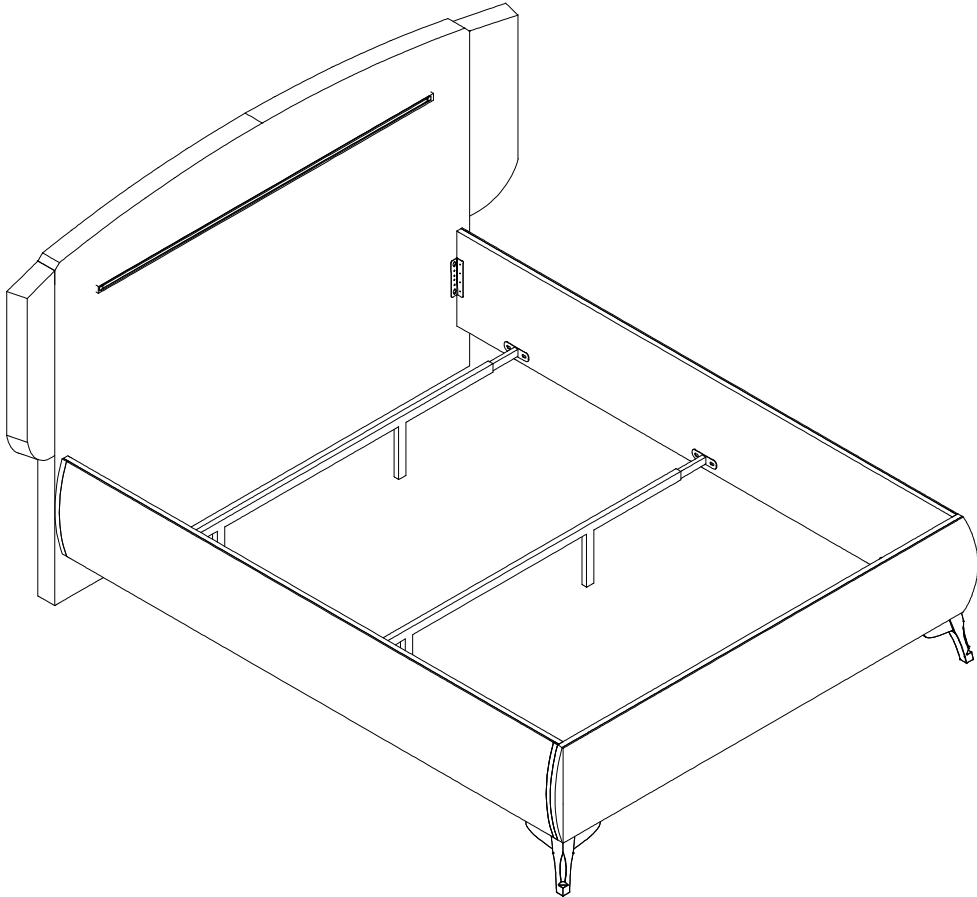
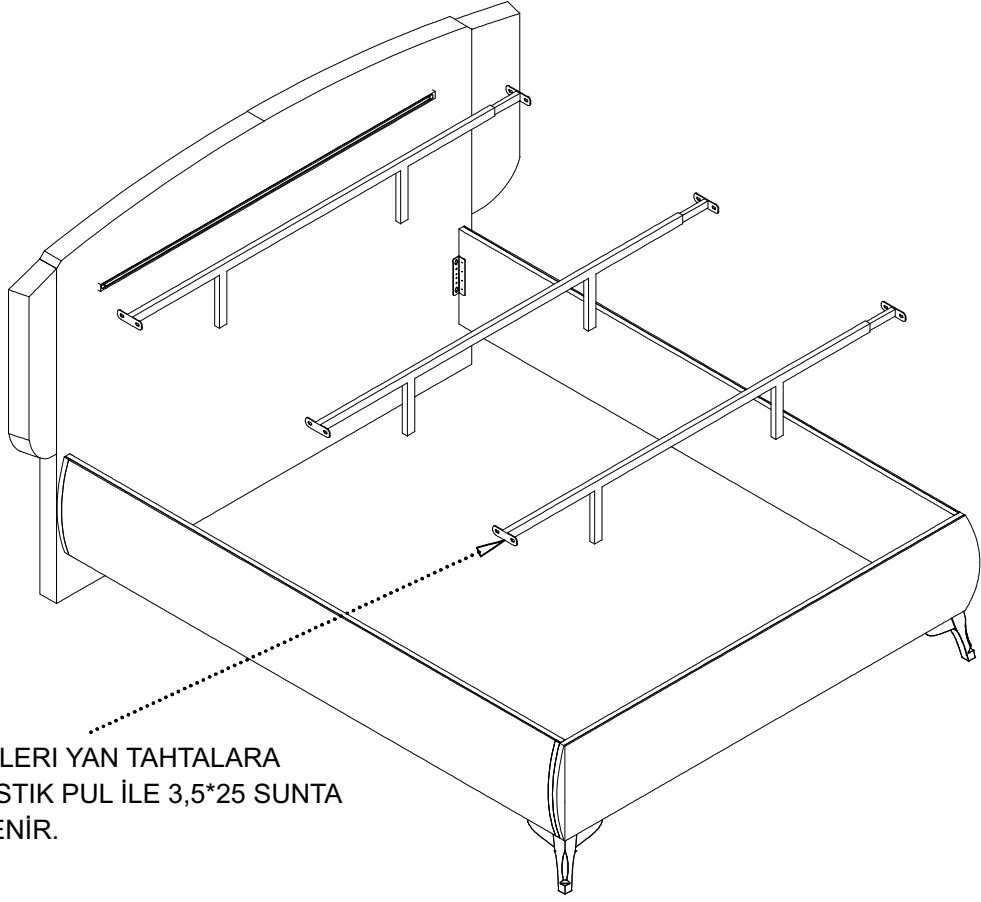

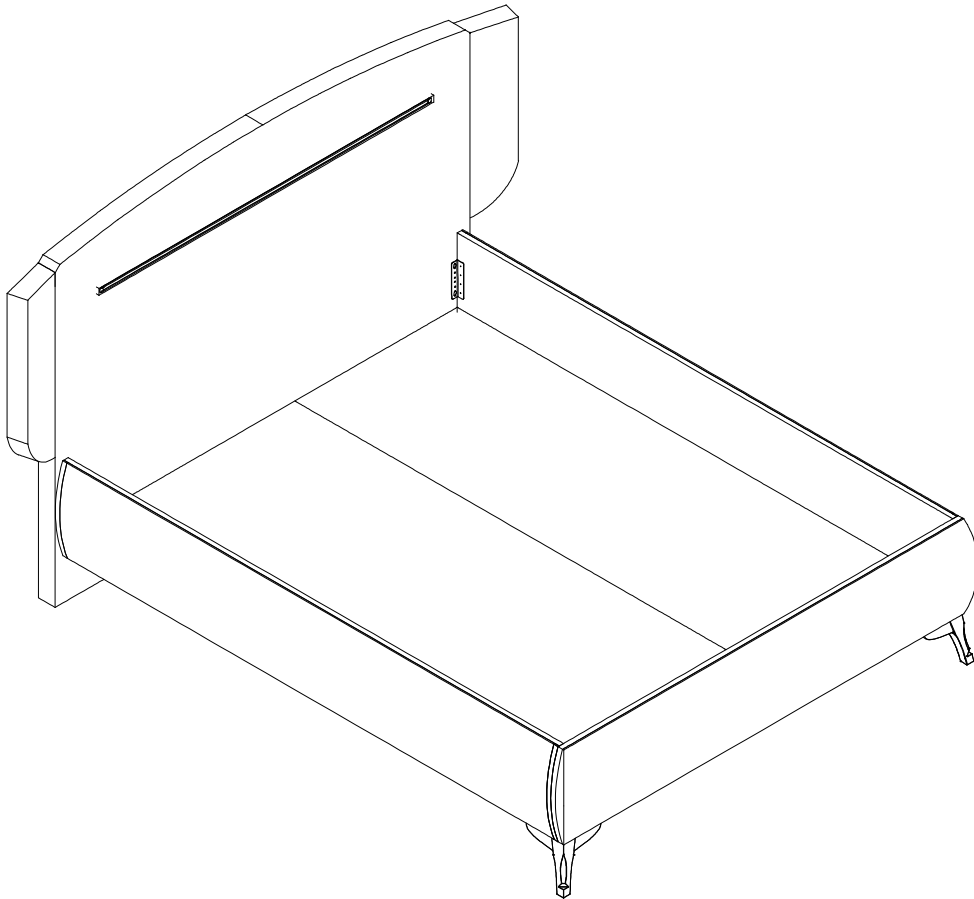
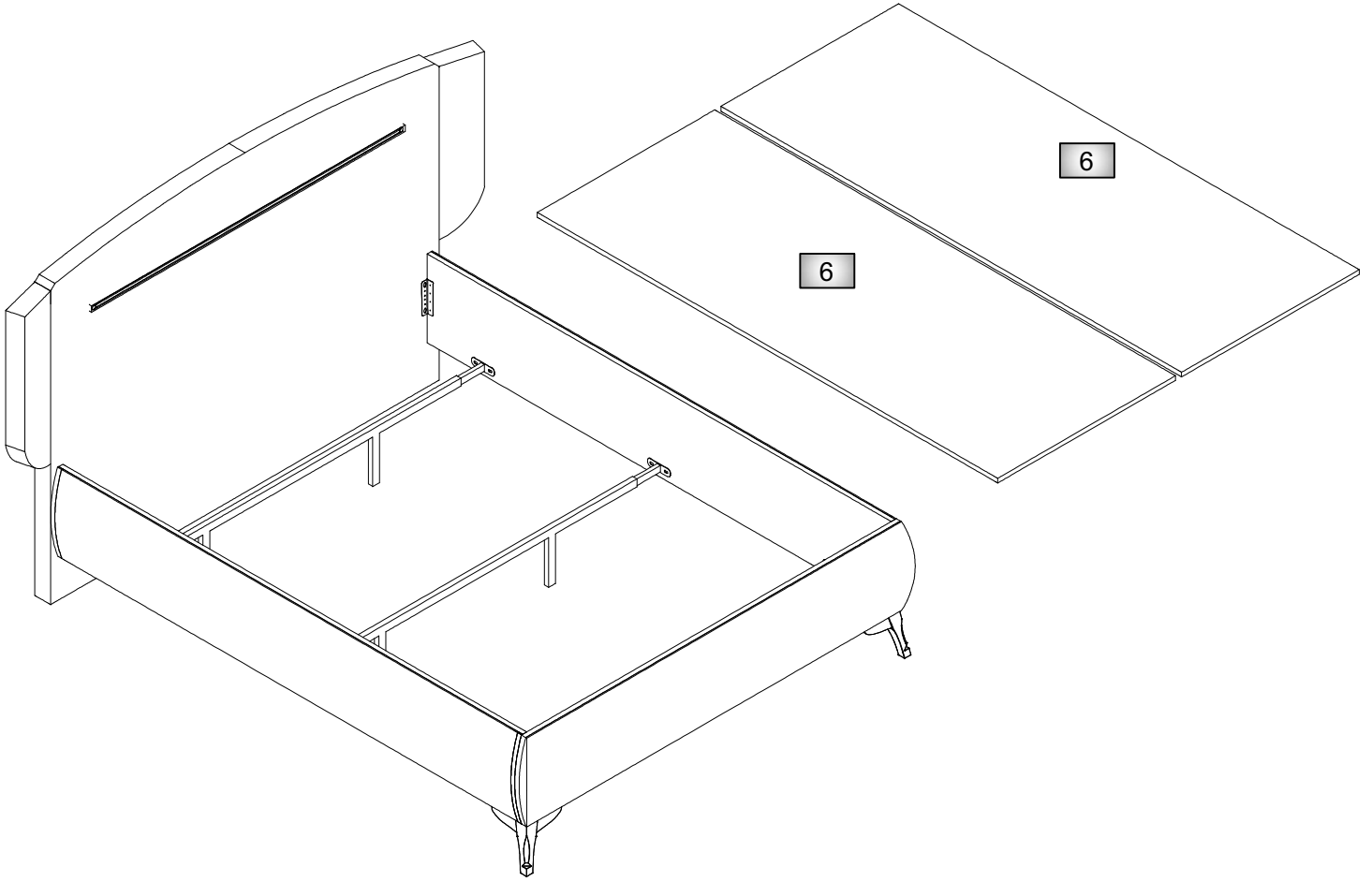

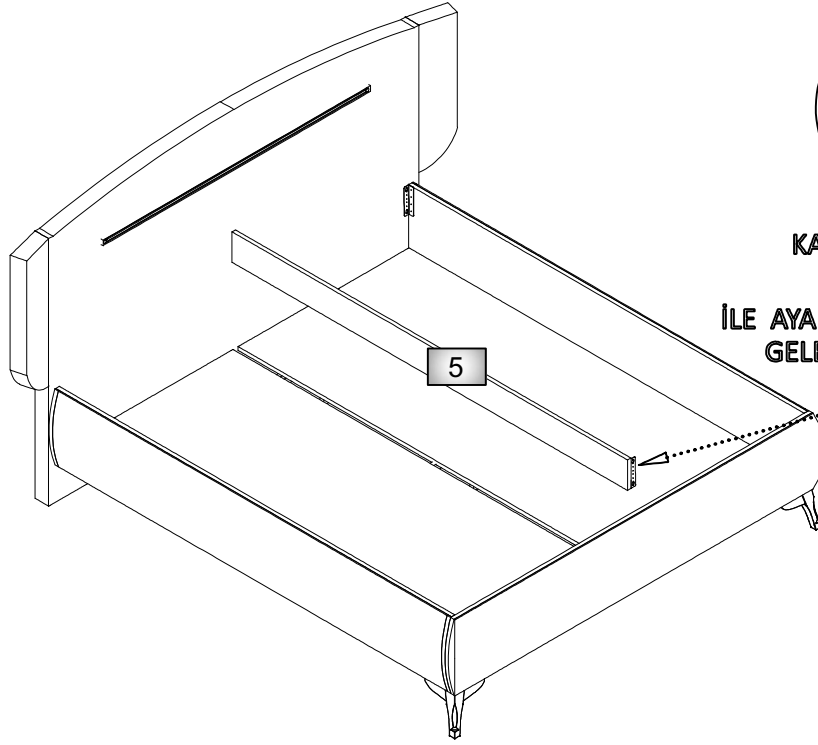

**KARYOLA BAĞLANTI DEMİRLER
3,5*25 SUNTA VİDALARI
İLE AYAKUCU VE BASUCUNA ORTA K
GELECEK ŞEKİLDE MONTAJI YAPIL**

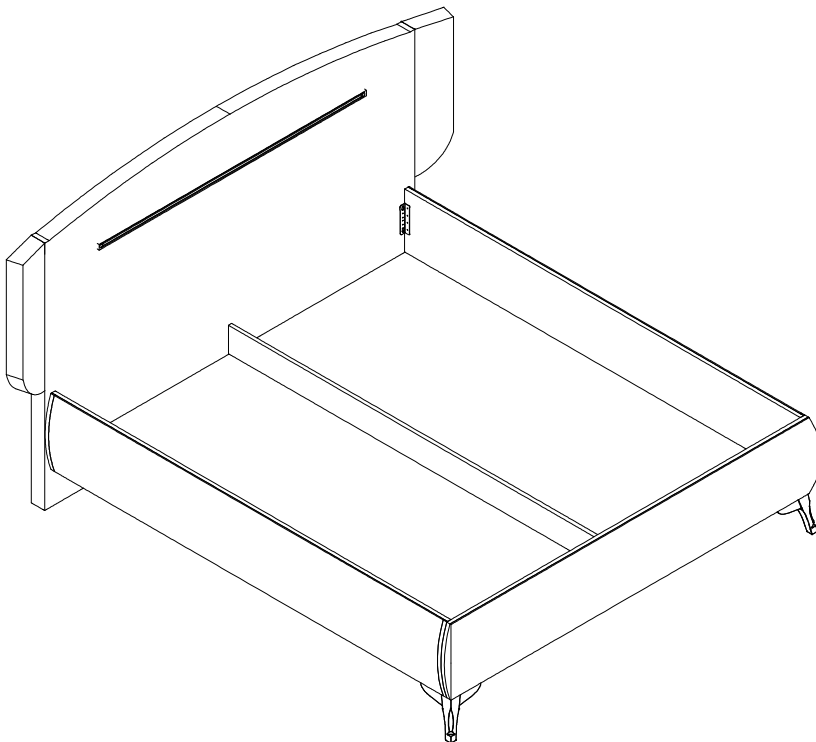

BAZA BARIYERLERİ YAN TRAVERSLERE 3,5*25 SUNTA VİDASI
İLE MONTAJI YAPILIR.

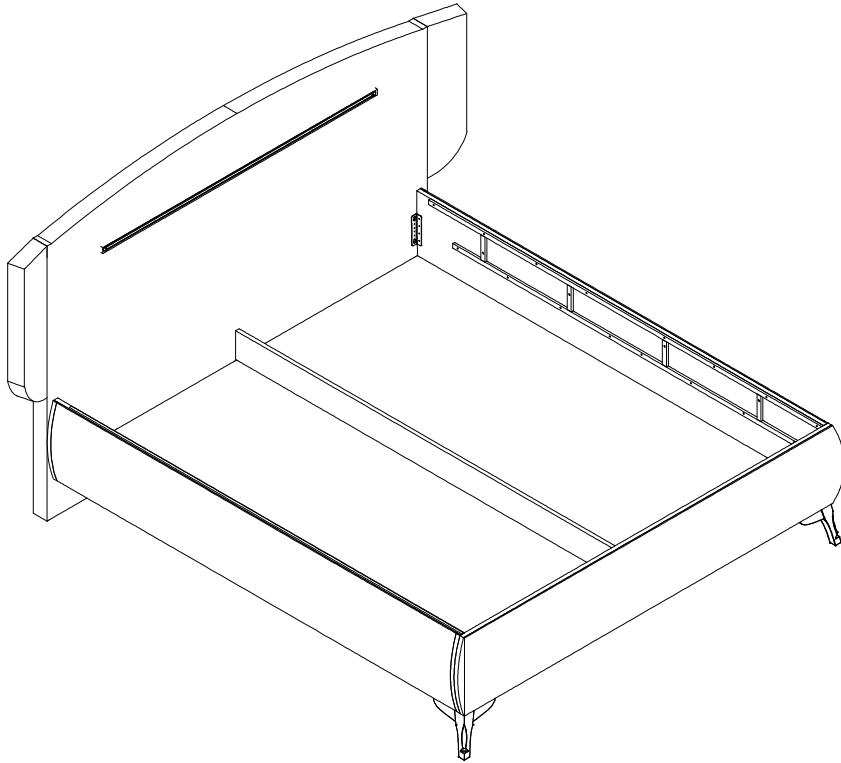
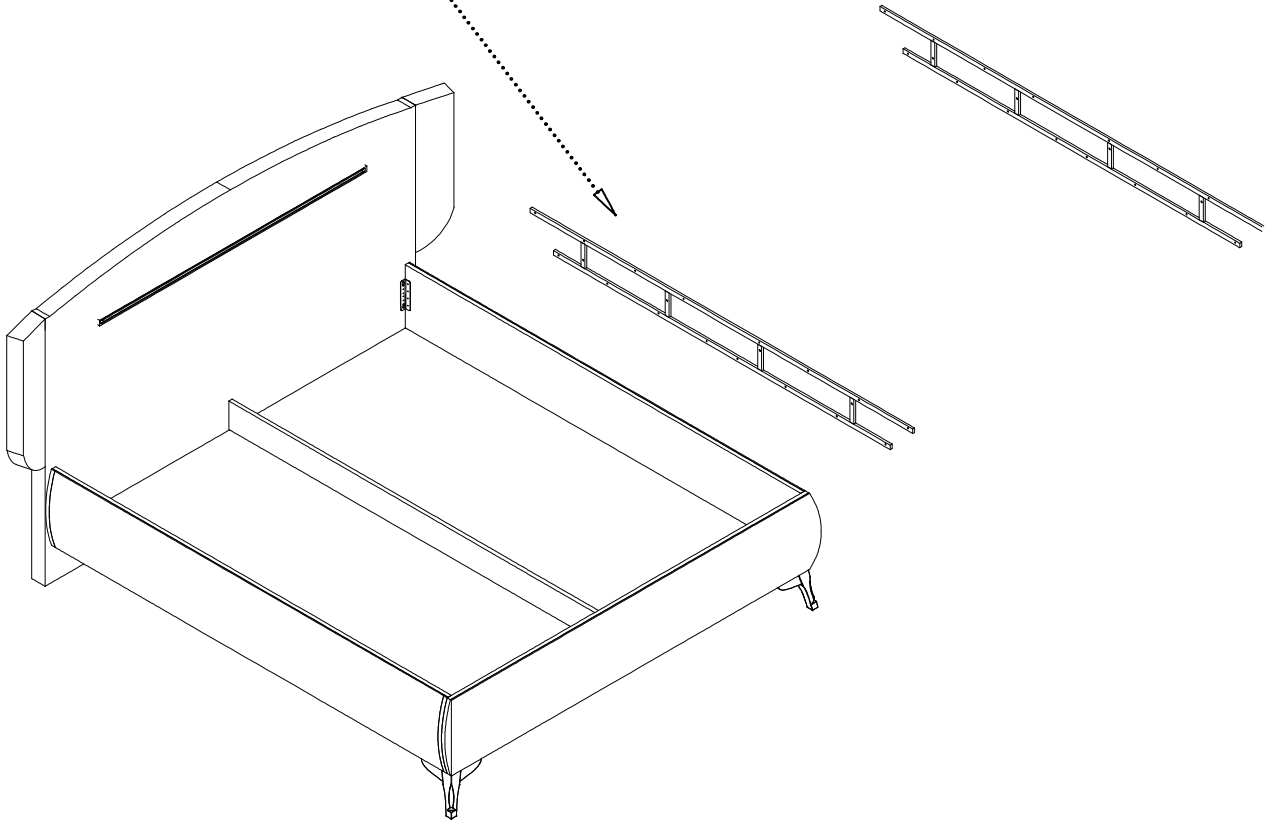

NOTE: BASE HEIGHT CAN BE ADJUSTED BY SCREWING UP
AND DOWN FROM THE HOLE LINE / NOT: TABAN YÜKSEKLİĞİ
DELİK HATINDAN YUKARI VE AŞAĞI VİDALANARAK
AYARLANABİLİR

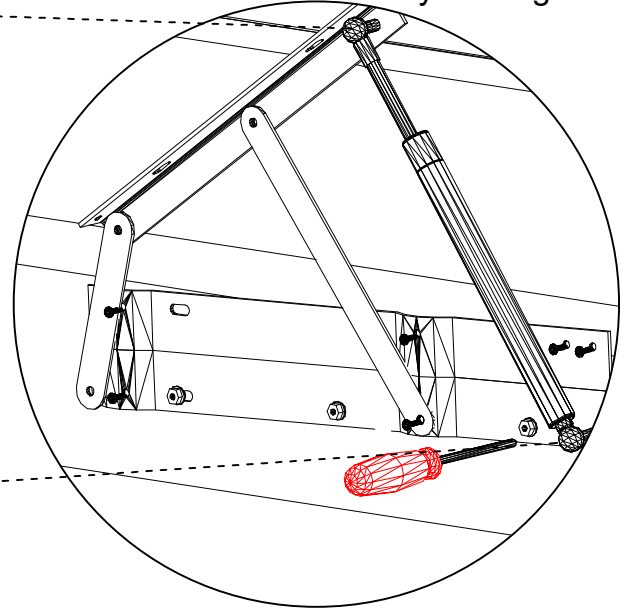

BAZA MAKASI METAL BARIYERLERE
ANAHTAR BASLI M8*15 VIDA ILE
SABITLENIR

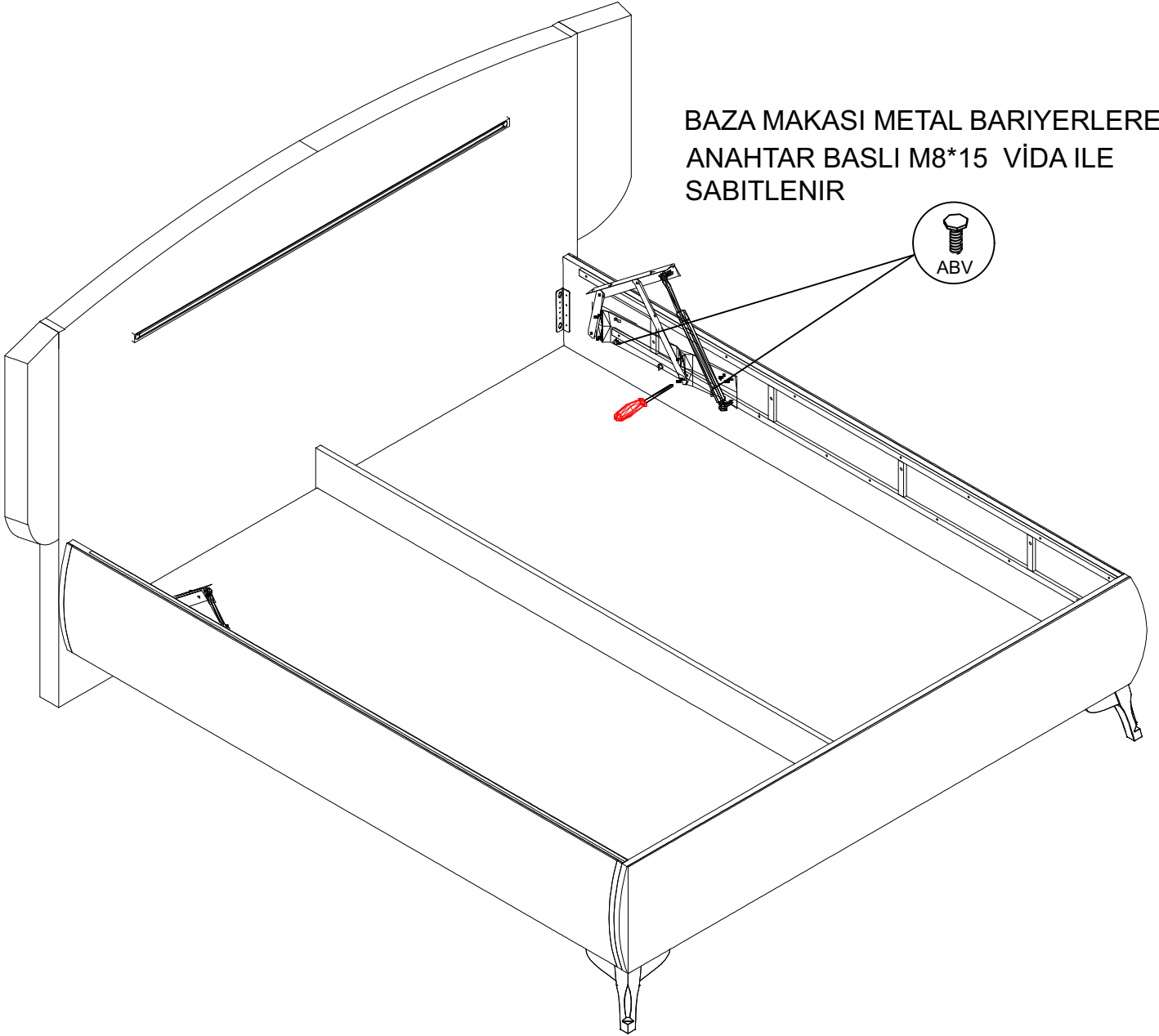
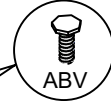

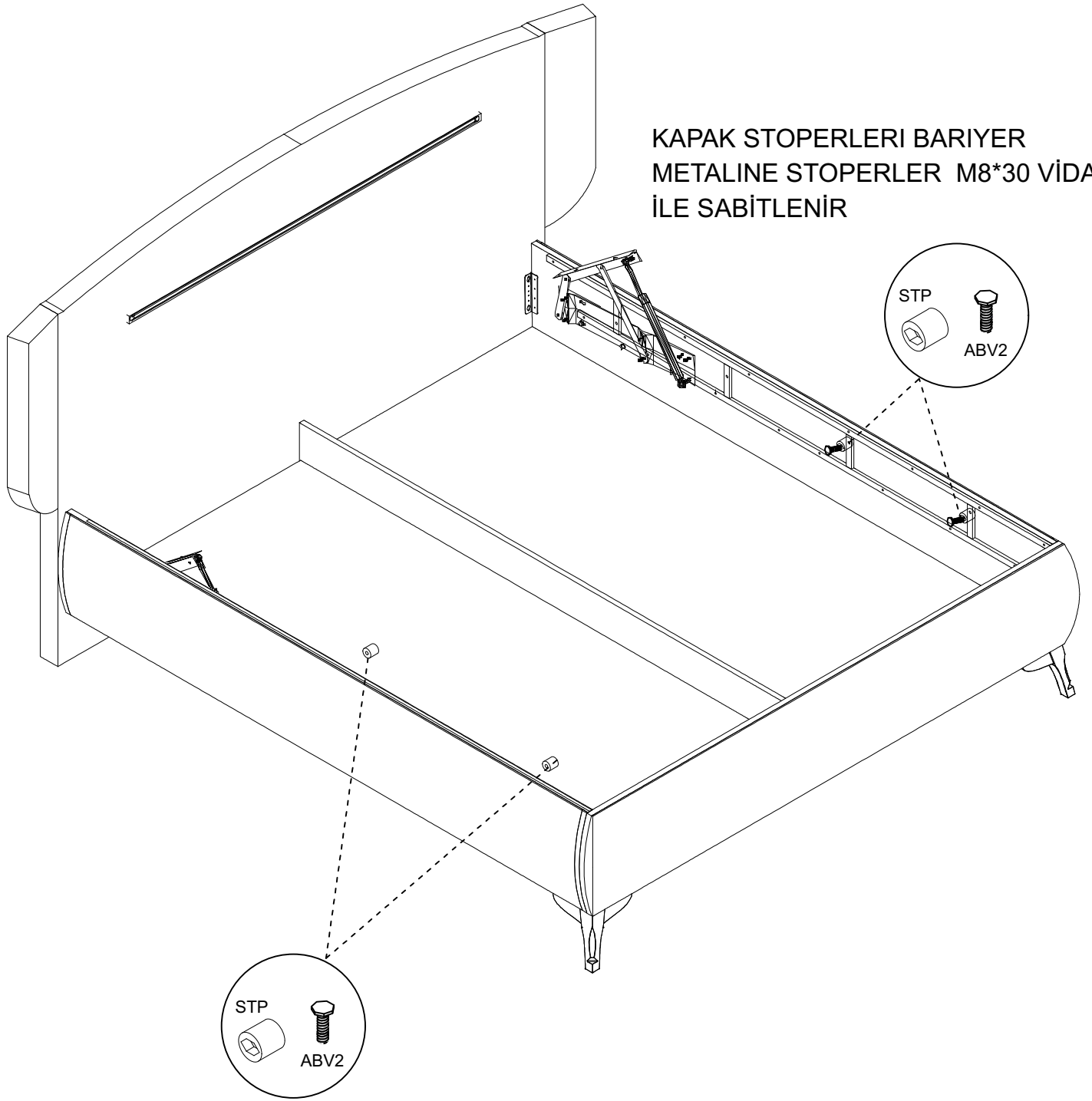

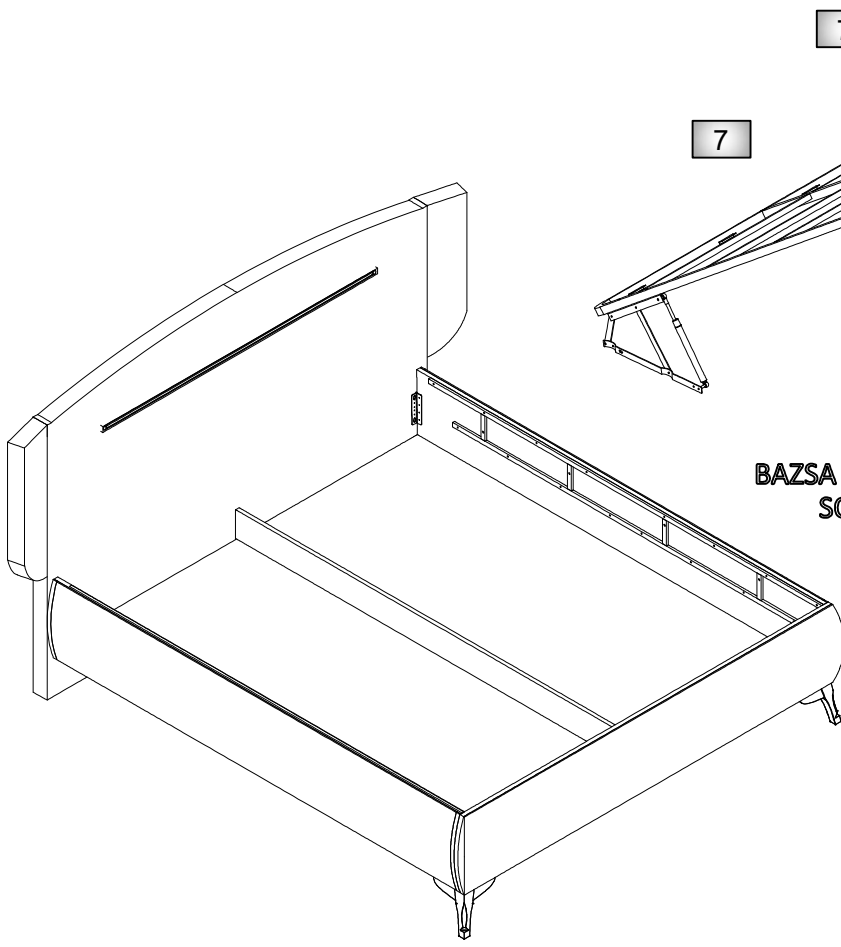

BAZSA METALİ PSİTON VE MAKASI TAKILDIKTAN
SONRA KARYOLAYA BAĞLATISI YAPILIR

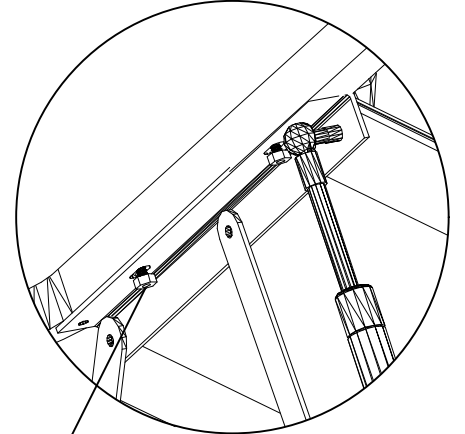

TIGHTEN THE NUT WITH A WRENCH FROM THE
BOTTOM BY ATTACHING THE BASE BAR AND
THROWING M6X50 SCREW / TABAN ÇUBUĞUNU
TAKARAK M8X50 VİDA ÇIKARARAK SOMUNU
ALTTAN ANAHTARI İLE SIKIN

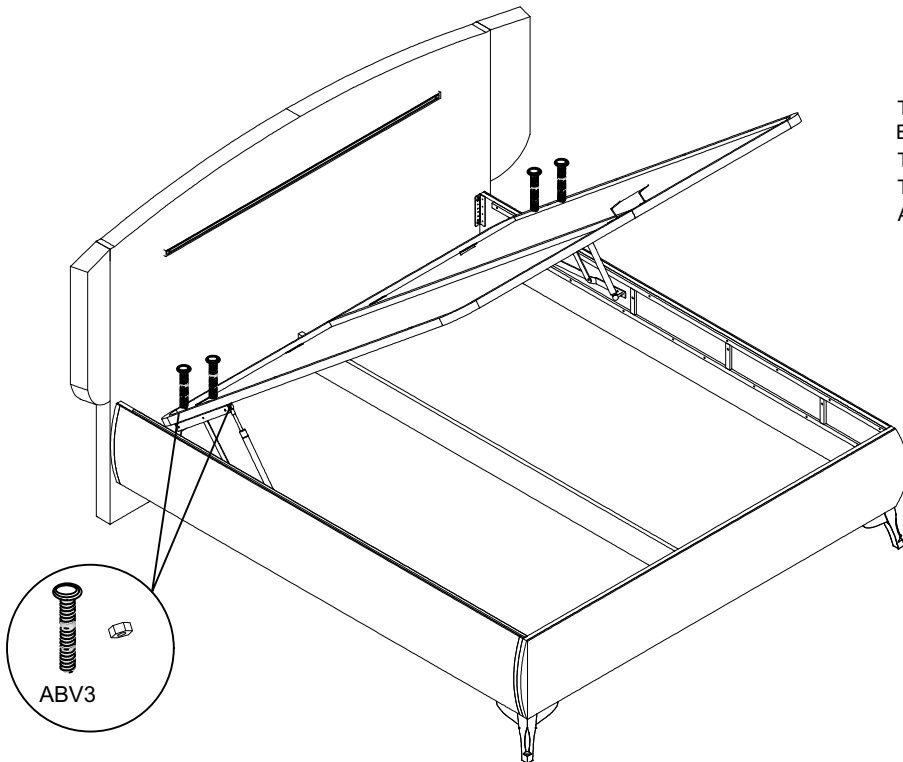

ABV3